



**BRAVO LCD & PLASMA
TV MOUNTING SOLUTIONS.**



ELEGANT, ROBUST, COMPREHENSIVE & AFFORDABLE

The Bravo range of High-Quality LCD/Plasma TV Brackets are designed and produced entirely in Italy. Manufactured from anodized aluminium, they are available in two attractive silk finishes, Black or Silver. The comprehensive range of 'Premium' and 'Low-cost' models ensures that all tastes can be satisfied.

15 - 30" TELEVISIONS

PREMIUM WALL SUPPORTS

LCD 1

- 15 - 30" LCD TV Wall Bracket
- Max. weight 20kg
- Adjustments: Tilt 15'
- Colour: Anodized Black or Silver

LCD 2

- 15 - 30" 2 Hinge LCD TV Support
- Max. weight 20kg
- Adjustments: Tilt 15' Swivel 90'
- Colour: Anodized Black or Silver

LCD 3

- 15 - 30" 3 Hinge LCD TV Support
- Max. weight 20kg
- Adjustments: Tilt 15' Swivel 90'
- Colour: Anodized Black or Silver

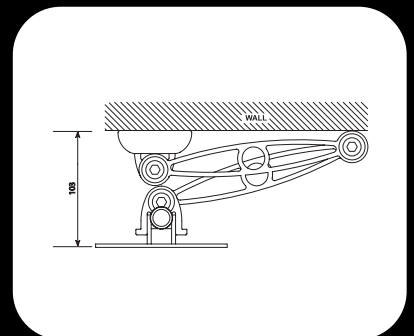
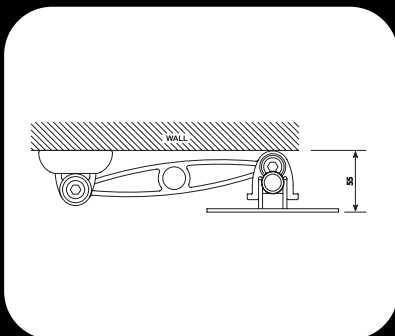
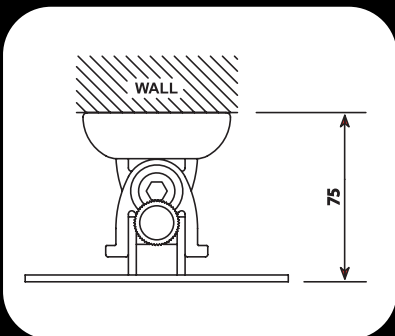
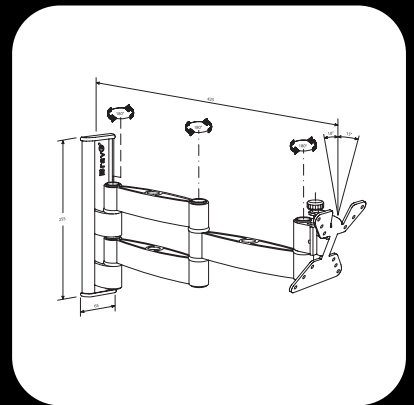
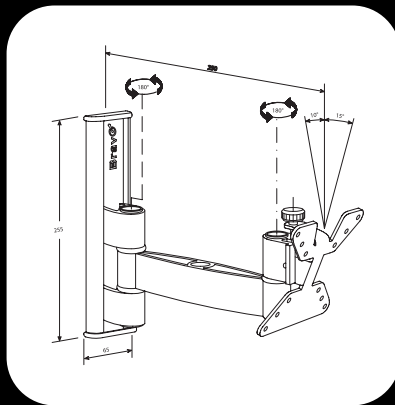
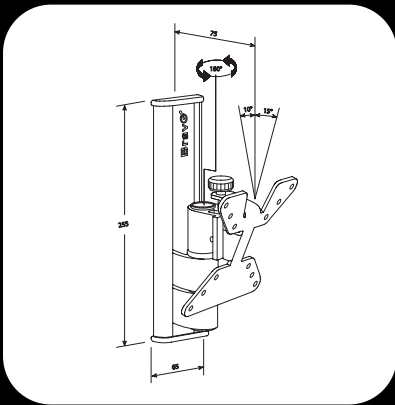

32 - 50" TELEVISIONS

PREMIUM WALL SUPPORTS

LCD 4

- 3 Hinge Dual Arm 32" LCD TV Support
- Max. weight 25kg
- Adjustments: Tilt 15° Swivel 60°
- Colour: Anodized Black or Silver
- Vesa size: 200 x 100mm

PLASMA 1

- 37 - 50" Plasma TV Wall Support
- Max. weight 45kg
- Adjustments: Tilt 15°
- Colour: Anodized Black or Silver

PLASMA 2

- 37 - 50" Plasma TV Wall Support
- Max. weight 45kg
- Adjustments: Tilt 15° Swivel 30°
- Colour: Anodized Black or Silver

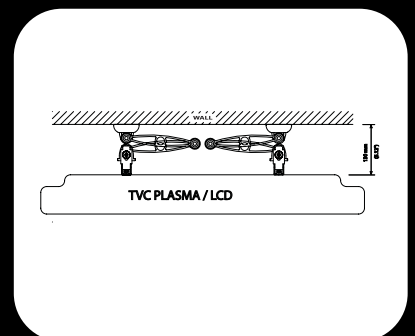
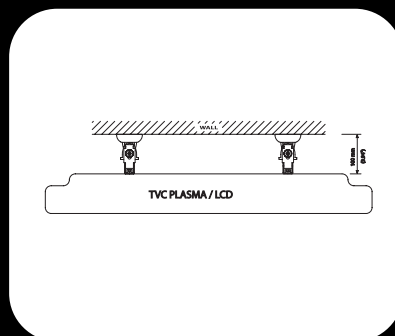
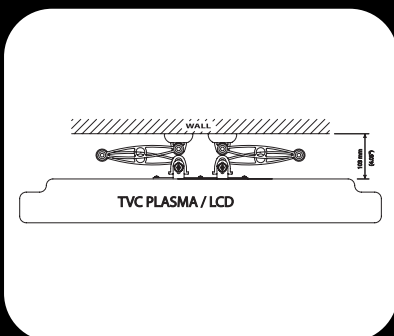
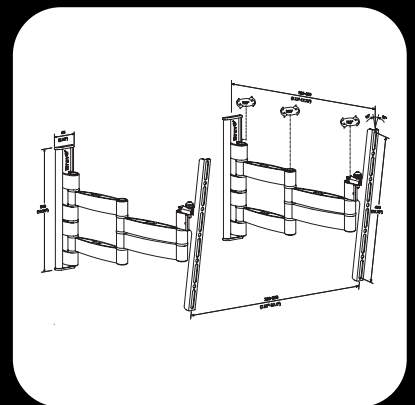
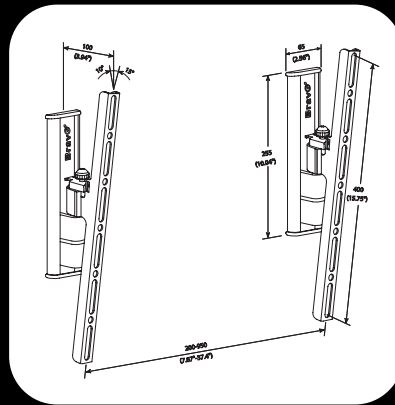
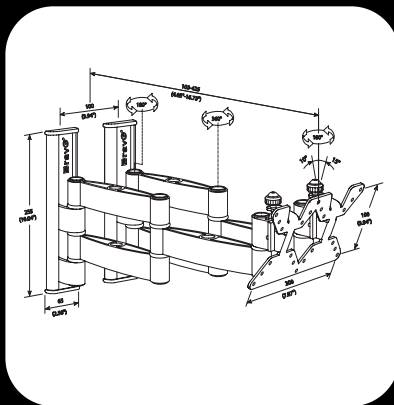

10 - 60" TELEVISIONS

LOW COST WALL SUPPORTS

WALL 1

- 21 - 32" LCD TV & Plasma Wall Bracket
- Max. weight 40kg

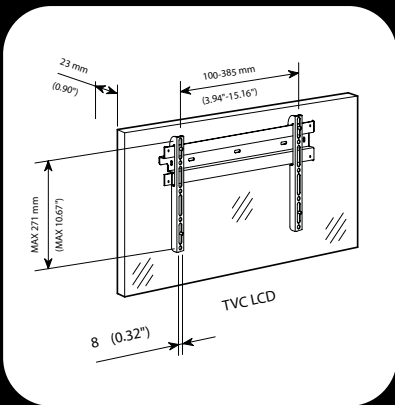
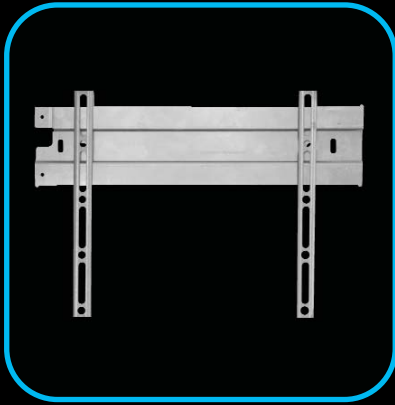

WALL 2

- 32 - 60" LCD TV & Plasma Wall Bracket
- Max. weight 60kg

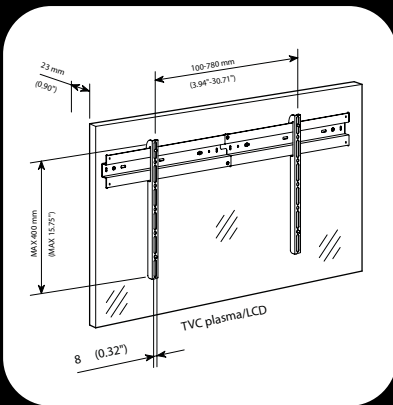
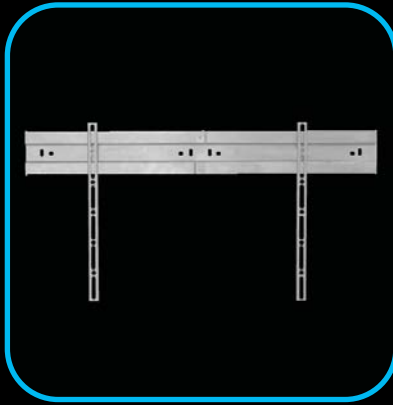

ERCOLE

- 10 - 26" low cost LCD TV Wall bracket
- Max. weight 17kg
- Finished in grey ABS

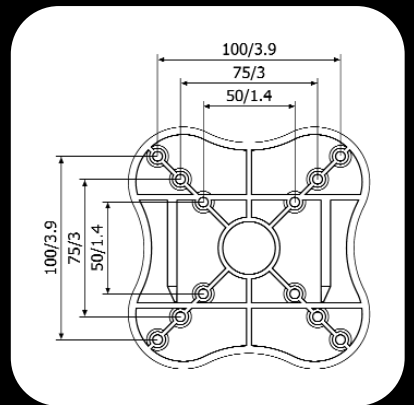

UNIVERSAL ADAPTOR

VESA

Universal adaptor for VESA connector

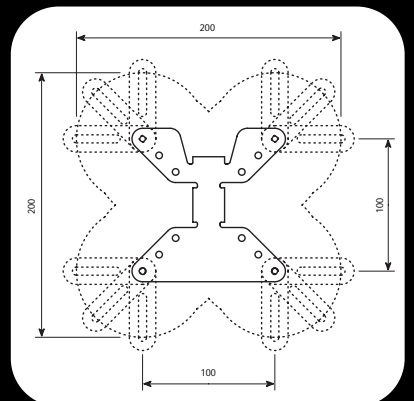

COMBINATION & COVER UNITS

WIRE COVER LINE

- Wire concealing unit
- Extends 25 - 130cm

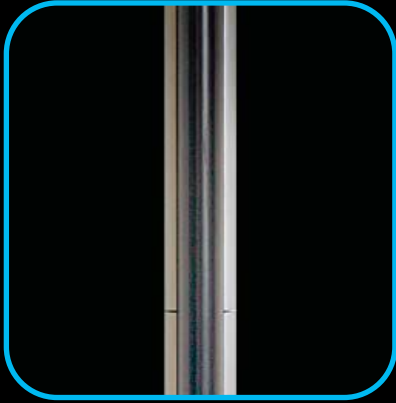

CRYSTAL 1 COMBI

- Wall mounting equipment shelf (for DVD/VCR/STB/SAT)
- Wire Cover Line (Wire covering system)



CRYSTAL 2 COMBI

- Twin wall mounting equipment shelves (for DVD/VCR/STB/SAT)
- Wire Cover Line (Wire covering system)

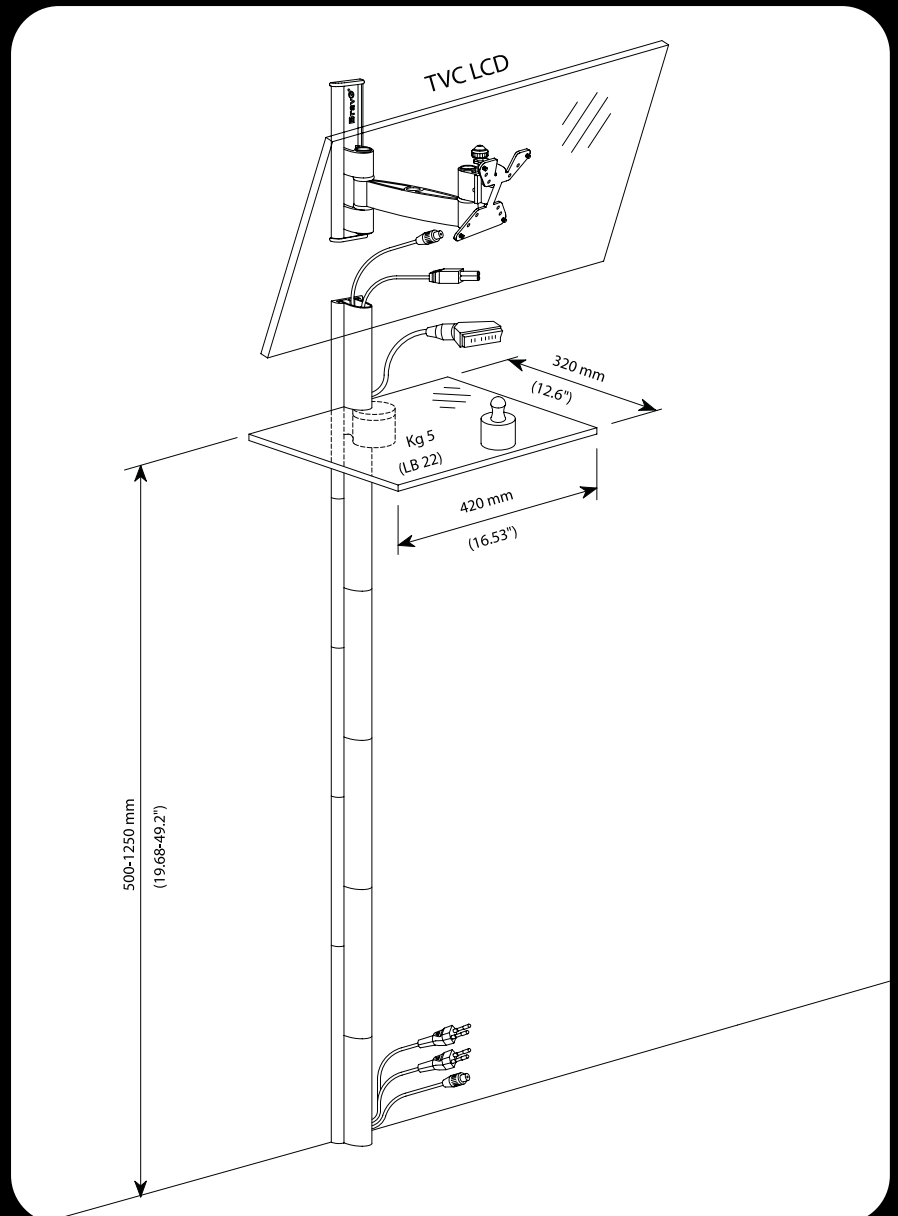

10-23" LCD MONITOR DESK BRACKET

PC 1

- 10 - 23" CD TV Wall Bracket
- Max. weight 15kg
- Adjustments: Tilt 15' Swivel 270'

PC 2

- 10 - 23" CD TV Wall Bracket
- Same as PC1 but twin monitor model.

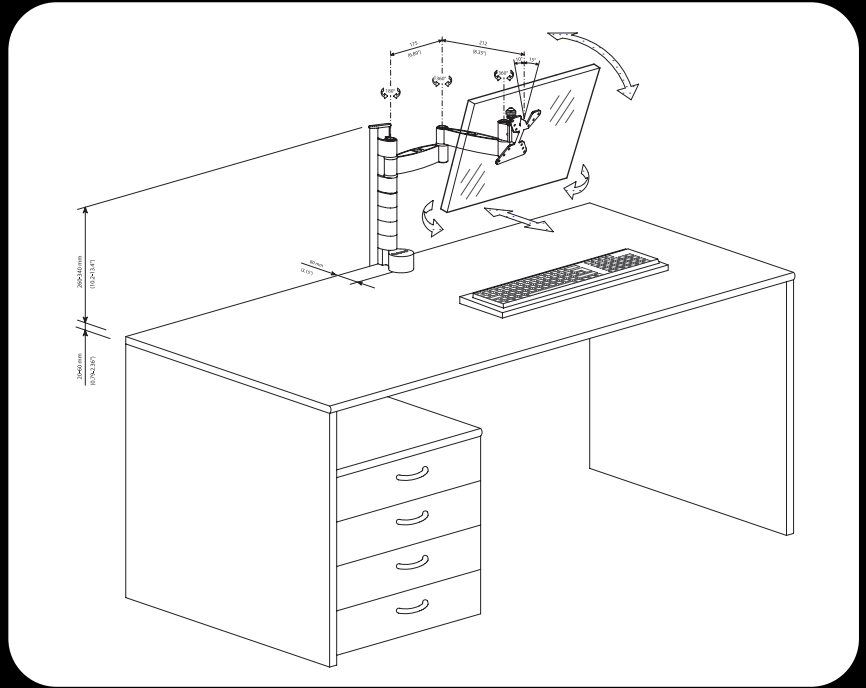

BRAVO PACKAGING





EASY TO ORDER

Its simple to order with Wallis UK. All we need is a purchase order number and orders can be placed by, Telephone, Fax, Email or Post.

WALLIS UK

A109 Riverside Business Centre, London, SW18 4UQ
Telephone: 020 8870 3388 • Fax: 020 8870 9988
Email: sales@wallis-universal.co.uk